

SI-9010
70MHz HIGH VOLTAGE DIFFERENTIAL PROBE
USER'S MANUAL

This probe is in compliance with IEC-61010-031, Pollution Degree 2.

1. Safety Terms and Symbols

Terms appear in this manual:



WARNING. Warning statements identify conditions or practices that could result in injury or loss life.



CAUTION. Caution statements identify conditions or practices that could result in damage to this product or other property.

Symbols appear on the product:



Danger
High Voltage



Protective
(Earth) Terminal



Attention
Refer to Manual

2. General Safety Summary

Review the following safety precautions to avoid injury and prevent damage to this probe or any products that connected to it.

Observe Maximum Working Voltage

To avoid any injury, does not use the probe under the condition that the voltage between either input lead or earth is above 2500Vrms CAT II, I between two inputs. This voltage rating applies to both of 1/100 & 1/1000 settings.

Must be Grounded

This probe is grounded with the shell of BNC connector and an auxiliary grounding terminal, through the grounding conductor of the power cord of the measurement instrument.

Before making connections to the input leads of this probe, ensure that the output BNC connector is attached to the BNC connector of the measurement instrument and the auxiliary grounding terminal is connected to a proper ground, while the measurement instrument is properly grounded.

Use Fused Test Prods if Necessary

If this probe is intended to use for measurements in circuits of INSTALLATION CATEGORY III, it should incorporate with fused test prods.

Do Not Operate Without Covers

To avoid electric shock or fire hazard, do not operate this probe with covers removed.

Do Not Operate in Wet/Damp Conditions

To avoid electric shock, do not operate this probe in wet or damp conditions.

Do Not Operate in Explosive Atmosphere

To avoid injury or fire hazard, do not operate this probe in an explosive atmosphere.

Avoid Exposed Circuit

To avoid injury, remove jewelry such as rings, watches, and other metallic objects. Do not touch exposed connections and components when power is present.

Use Proper Power Source

To ensure this probe function well, use four AA cells or 6VDC/200mA or regulated 9VDC/120mA mains adaptor or power leads. Do not operate this probe from a power source that applies more than the voltage specified.

Do Not Operated With Suspected Failures

If you suspect there is damage to this probe, have it inspected by qualified service personnel.

3. Description

By enabling conventional oscilloscopes to display and measure in-circuit waveforms that are referenced to high common mode voltages. The differential probe extends the measurement capability of oscilloscopes in electronic power converters, inverters, motor speed controls, switch mode power supplies and many applications.

4. Installation

- a. Simply plug-in the output BNC connector of this probe to the vertical input of a general purposed oscilloscope or other measurement instrument, and connects the auxiliary grounding terminal to a proper ground. The measurement instrument must have a ground referenced.
- b. Connect an appropriate power source to this probe and then turn it on.
- c. Select the proper attenuation ratio. When measuring signals below 700V, switch the attenuation ratio to 1/100 in order to get higher resolution and less noise ratio. Otherwise, set the attenuation ratio to 1/1000 when measuring signals up to 7000V.



WARNING. To protect against electric shock, use only the accessories supplied with this probe.

- d. Using the appropriate probe accessories, connect the inputs to the circuits under measurement.



CAUTION. This probe is carry out differential measurement between two points on the circuit under measurement. This probe is not for electrically insulating the circuit under measurement and the measuring instrument.

5. Appearance

The differential probe looks as follows.

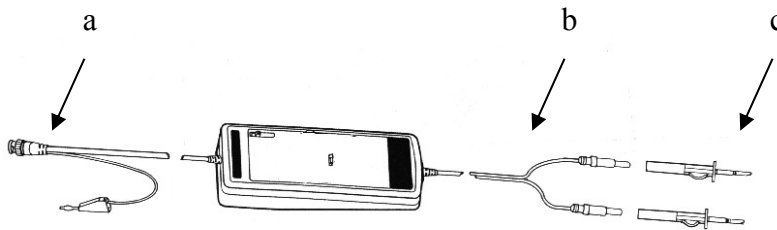

- a. Output Lead The BNC output connector and an auxiliary grounding terminal are connected to the oscilloscope.
- b. Input Leads The input leads of the differential probe connect to sprung hooks that come with the probe.
- c. Sprung Hooks The sprung hooks are connected safely to test points in circuits under measurement.

6. Power Leads

We offer two types power leads;

- a. Adaptor-Lemo[®] Lead: For the oscilloscope whose power connector is Lemo[®] connector.
- b. USB Power Cord: For the oscilloscope which offers USB connector.

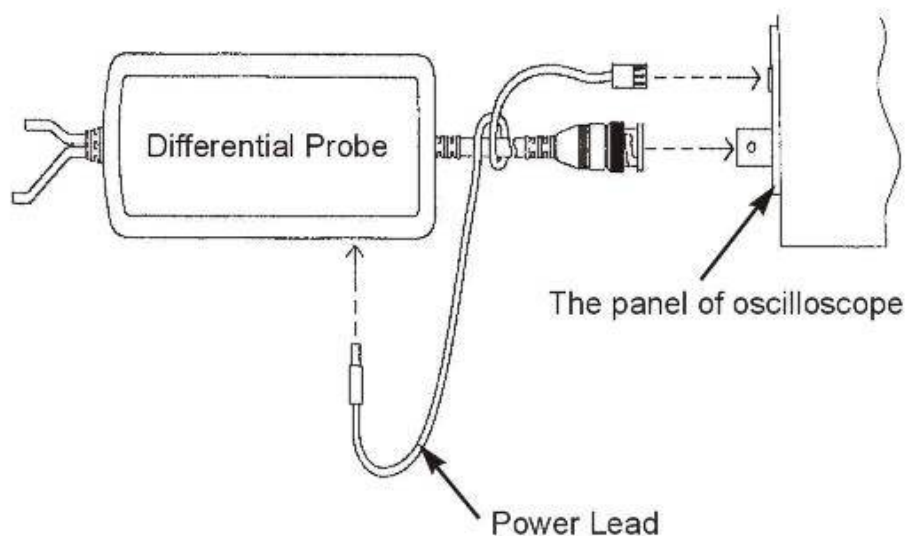

7. Specifications

Bandwidth	DC to 70MHz (-3dB)
Attenuation	1:100/1000
Accuracy	±2%
Rise Time	<5ns
Input Impedance	10MΩ//10pF each side to ground
Input Voltage	
- Category	CAT I
- Differential Range	700V _{rms} and ±700V(DC+Peak AC) @1/100 5000V _{rms} and ±7000V(DC+Peak AC) @1/1000
- Common Mode Range	2500V _{rms} and ±7000V(DC+Peak AC) @1/100 & 1/1000
- Absolute Max. Voltage	2500V _{rms} and ±7000V(DC+Peak AC) @1/100 & 1/1000 in common mode 5000V _{rms} and ±7000V(DC+Peak AC) @1/100 & 1/1000 in differential mode
Output Voltage	
- Swing	±7V (into 50kΩ load)
- Offset (typical)	<±5mV
- Noise (typical)	0.9mV _{rms}
- Source Impedance (typical)	50Ω (for using 1MΩ input system oscilloscope)
CMRR (typical)	-80dB@50Hz, -60dB@20kHz
Ambient Operating Temperature	-10 to 40°C
Ambient Storage Temperature	-30 to 70°C
Ambient Operating Humidity	Up to 85% RH
Ambient Storage Humidity	Up to 85% RH
Power Requirements*	
- Standard	4xAA cells
- Options	Power leads, Mains adaptor* (6VDC/200mA or regulated 9VDC/120mA), USB power cord
Length of BNC Cable	90cm
Length of Input Leads	60cm
Weight	500g
Dimension (LxWxH)	202mmx83mmx38mm

* a. The supplied voltage must be less than 12V and greater than 4.4V, otherwise the probe could be damaged or can't operated properly.

b. Polarity is “+” inside and “-” outside. For wrong polarity, built-in circuit protects the probe, no danger or damage will occur.

c. When the voltage of the cells become too low, the power indicator on the panel will flicker.

8. Derating Curve

The derating curve of the absolute maximum input voltage in common mode is shown as follows;

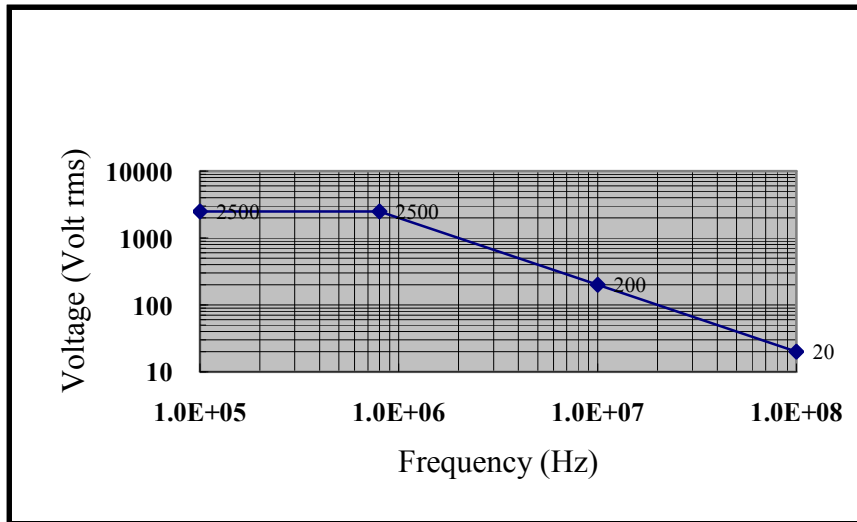

9. Overrange Indicator

The overrange indicator lights red, if the voltage of the input signal exceeds the linear operating range of the probe. When this happens, the signal on the probe output may not accurately represent the signal on the probe input.

10. Inspection Procedure

- Connect the BNC output connector to the vertical input of a general purposed oscilloscope.
- Install four AA cells or connect an appropriate power source to this probe.
- Set the oscilloscope input to DC coupling and 1V/div. Center the trace on the display.
- Connect the sprung hooks of the probe to power lines.
- Set the range of the probe to 1/1000.
- Then, a 50Hz/60Hz sine-wave of proper amplitude will be displayed on the screen of the oscilloscope and this means this probe is working properly.

11. Cleaning

Use a soft cloth to clean the dirt. Prevent damage to probe.

- Avoid immersing the probe.
- Avoid using abrasive cleaners.
- Avoid using chemicals contains benzene or similar solvents.