

**1.5GHz HIGH FREQUENCY DIFFERENTIAL PROBE
USER'S MANUAL**

This probe is in compliance with IEC61010-031, Pollution Degree2.

1. Safety Terms and Symbols

Terms appear in this manual:



WARNING. Warning statements identify conditions or practice that could result in injury or loss life.



CAUTION. Caution statements identify conditions or practice that could result in damage to this product or other property.

Symbols appear on the product:



Danger
High Voltage



Protective
(Earth) Terminal



Attention
Refer to Manual

2. General Safety Summary

Review the following safety precautions to avoid injury and prevent damage to this probe or any products that connected to it.

Observe Maximum Working Voltage

To avoid any injury, do not use the probe under the condition that the voltage between either input lead and earth is above 40Vrms.

Must be Grounded

This probe is grounded with the shell of BNC connector, through the grounding conductor of the power cord of the measurement instrument.

Before making connections to the input leads of this probe, ensure that the output BNC connector is attached to the BNC connector of the measurement instrument which is properly grounded.

Do Not Operate Without Covers

To avoid electric shock or fire hazard, do not operate this probe with covers removed.

Do Not Operate in Wet/Damp Conditions

To avoid electric shock, do not operate this probe in wet or damp conditions.

Do Not Operate in Explosive Atmosphere

To avoid injury or fire hazard, do not operate this probe in an explosive atmosphere.

Avoid Exposed Circuit

To avoid injury, remove jewelry such as rings, watches, and other metallic objects. Do not touch exposed connections and components when power is present.

Use Proper Power Source

To ensure this probe functions well, use one 9V battery or 6VDC/500mA or 9VDC/300mA mains adaptor or power lead.

Do Not Operate With Suspected Failures

If you suspect there is damage to this probe, have it inspected by qualified service personnel.

3. Description

By enabling conventional oscilloscopes to display and measure in-circuit waveforms that are inherently differential signals, the differential probe extends the measurement capability of oscilloscopes in digital communication and high speed digital circuits.

4. Installation

- a. Simply plug-in the BNC output connector to the vertical input of a general purposed oscilloscope or other measurement instrument to a proper ground. The measurement instrument must have a ground referenced.
- b. Connect an appropriate power source to this probe and then turn it on.



WARNING. To protect against electric shock, use only the accessories supplied with this probe.

- c. Using the appropriate probe accessories, connect the inputs to the circuits under measurement.



CAUTION. This probe is to carry out differential measurement between two points on the circuit under measurement. This probe is not for electrically insulating the circuit under measurement and the measuring instrument.

5. Appearance

The differential probe looks as follows.

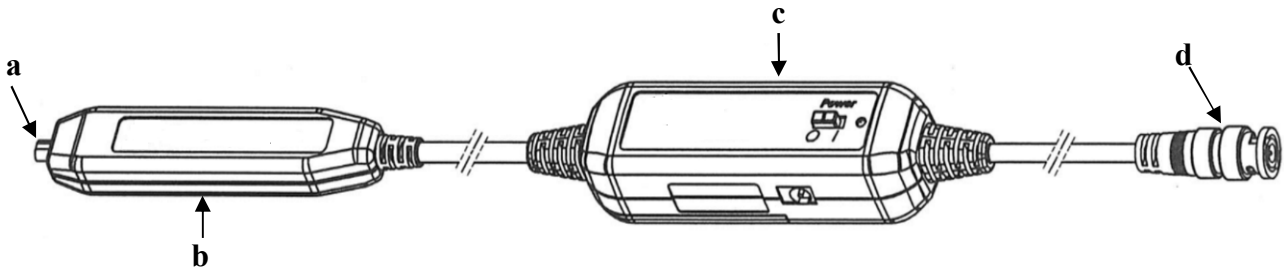

- a. Input Pins: The input pin of the differential probe can be connected directly to the circuit under test or connected to optional accessories that come with the probes
- b. Probe Body
- c. Power Unit: Power source as follows;
 - Mains adaptor (6VDC/500mA or 9VDC/300mA) or
 - 9V battery
 - Power lead
- d. Output Cable: The BNC output connector is connected to the oscilloscope.

6. Power Unit

The following figure illustrates the operation of the power unit;

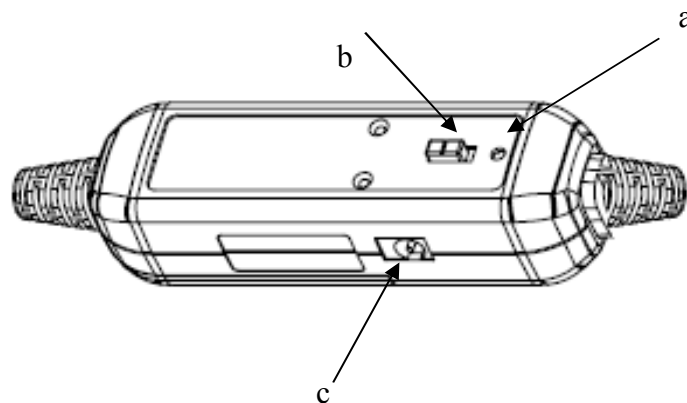

- a. LED indicator (green for normal operation, and turn to red when the voltage is too low)
- b. I/O switch
- c. Power jack

7. Specifications

Bandwidth	DC to 1.5GHz (-3dB)
Attenuation Ratio	1:10
Accuracy	±1%
Rise Time	233psec (Typical)
Input Impedance	104KΩ//1pF each side to ground
Input Voltage	
- Differential Range	±20V(DC+AC Peak) and 20Vrms
- Common Mode Range	±40V(DC+AC Peak) and 40Vrms
- Absolute Max. Voltage	±40V(DC+AC Peak) and 40Vrms
Output Voltage	
- Swing	±2V (into 50Ω load)
- Offset (typical)	<±5mV
- Noise (typical)	0.5mVrms @20MHz bandwidth limit
- Source Impedance (typical)	50Ω (for using 50Ω input system oscilloscope)
CMRR (typical)	-60dB @60Hz, -46dB @ 10MHz -26dB @100MHz, -15dB @ 1GHz
Power Requirements*	
- Standard	One 9V battery
- Options	Power leads, Mains adaptor* (6VDC/500mA or regulated 9VDC/300mA)
Ambient Operating Temperature	-10 to 40°C
Ambient Storage Temperature	-30 to 70°C
Ambient Operating Humidity	Up to 85% RH
Ambient Storage Humidity	Up to 85% RH
Length of BNC Cable	120cm
Weight	170gms
Dimensions (LxWxH)	111mm x 22mm x 14mm

- * a. The supplied voltage must be less than 10V and greater than 4.5V, otherwise the probe could be damaged or can't be operated properly.
- b. The polarity is “+” inside and “-” outside. For wrong polarity, built-in circuit protects the probe, no danger or damage will occur.
- c. When the voltage of the cells become too low, the power indicator on the panel will flicker.

8. SMD Micro Test Accessories

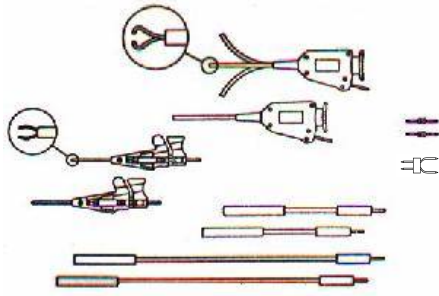

Description	Quantity
MicroFlex Pincer, Black	1
MicroFlex Pincer, Red	1
Micro Test Clip, Black	1
Micro Test Clip, Red	1
MicroLead, 0.8mm J-P, 5cm, Black	1
MicroLead, 0.8mm J-P, 5cm, Red	1
MicroLead, 0.8mm J-P, 10cm Black	1
MicroLead, 0.8mm J-P, 10cm Red 1	1
Variable Pitch Accessory (VPA)	2
Test Tip, 0.8mm	6

9. Derating Curve

The derating curve of the absolute maximum input voltage in common mode is shown as follows;

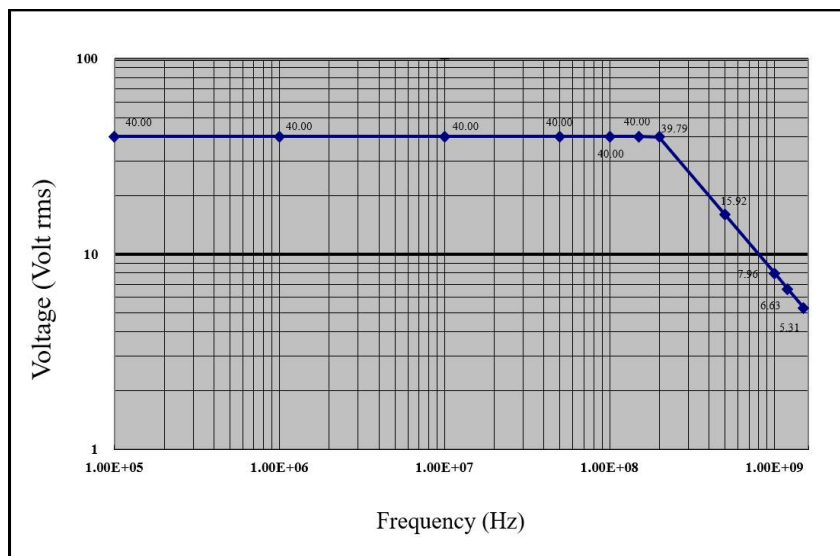

10. Inspection Procedure

- Connect the BNC output connector to the vertical input of a general purposed oscilloscope.
- Connect an appropriate power source to this probe and then turn it on.
- Set the oscilloscope to DC coupling and 0.5V/div. Center the trace on the display.
- Connect the inputs of the probe to a sine-wave signal source of 100KHz and 10Vp-p.
- Then, a 100KHz sine-wave of 1V amplitude will be displayed on the screen of the oscilloscope and this means the probe is working properly.

11. Cleaning

Use a soft cloth to clean the dirt to prevent damage to probe.

- Avoid immersing the probe.
- Avoid using abrasive cleaners.
- Avoid using chemicals contains benzene or similar solvents.