

Sapphire Instruments Co., Ltd.

Calibration Procedure of SI-50

This procedure is for use by qualified service personnel to adjust SI-50 properly.

The equipments required are listed in Table 1.

No.	Item	Minimum Requirements
1	Power Supply	6 VDC/90mA or 9 VDC/ 330 mA mains adaptor or 4xAA cells or power lead
2	DMM	DC Accuracy < 0.5%
3	Function Generator	Maximum Frequency > 10 MHz Sine-wave Distortion < 1%
4	Oscilloscope	Bandwidth \geq 20 MHz Accuracy \leq 2 %

Table 1.

This procedure is divided into following steps:

- A. Prepare the probe for adjustment.
- B. Adjust input bias voltage: VRA.
- C. Adjust output offset voltage: VRC.
- D. Adjust square-wave compensation for +input: VCA.
- E. Adjust square-wave compensation for -input: VCB.
- F. Adjust CMRR at 60 Hz: VRB.
- G. Adjust CMRR at 1 MHz: VCB

- A. Prepare the probe for adjustment.

A-1. Use a small flat screwdriver to peel the both panels off, referring to Fig.1.



Fig. 1

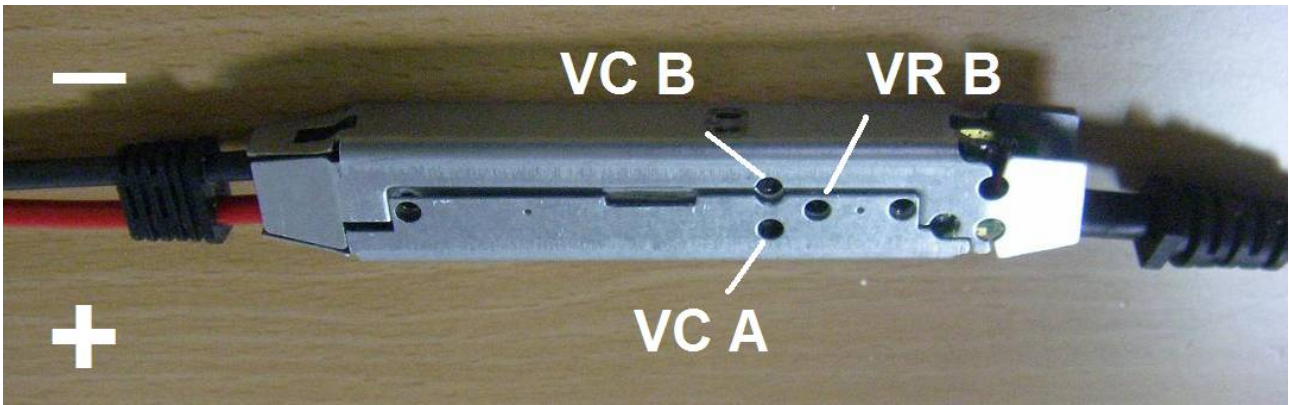

Fig.1a.

- A-2. Loosen the four screws on the plastic cases. referring to Fig. 1a.
- A-3. Remove the plastic cases. Fig.2 shows the location of adjustments on topside and bottom side of the metal case.
- A-4. Connect the power source.
- A-5. Allow the probe and test equipments to warm up 20 minutes at an ambient temperature of 18 degree Celsius to 28 degree Celsius.
- A-6. In order to make following operation easier, use one plastic case to support the metal case and the input head.



Top side



Bottom side

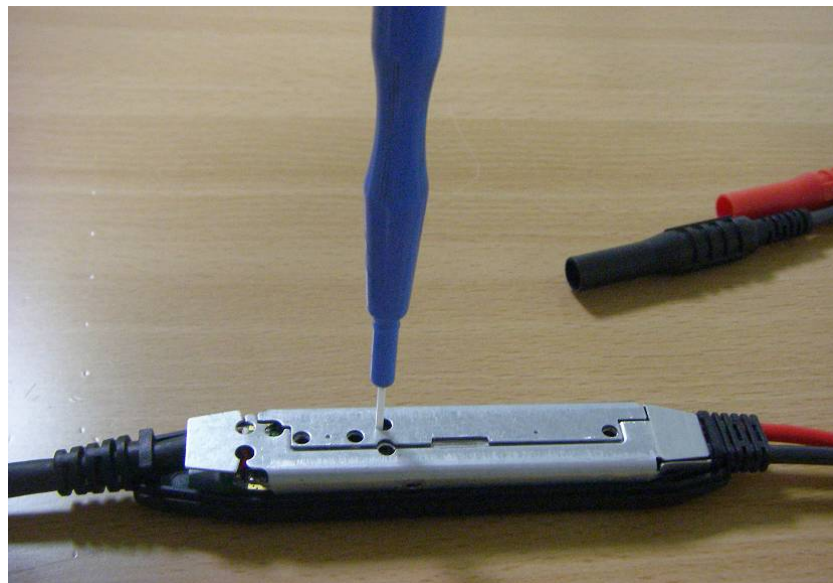

Fig. 2

B. Adjust input bias voltage

B-1. Connect the probe as shown in Fig.3.

B-2. The value of input bias voltage now is displayed on the digital multimeter.

B-3. Adjust VRA to make the input bias voltage as small as possible.

B-4. The criterion is $-3 \text{ mV} \leq V_{ib} \leq +3 \text{ mV}$.

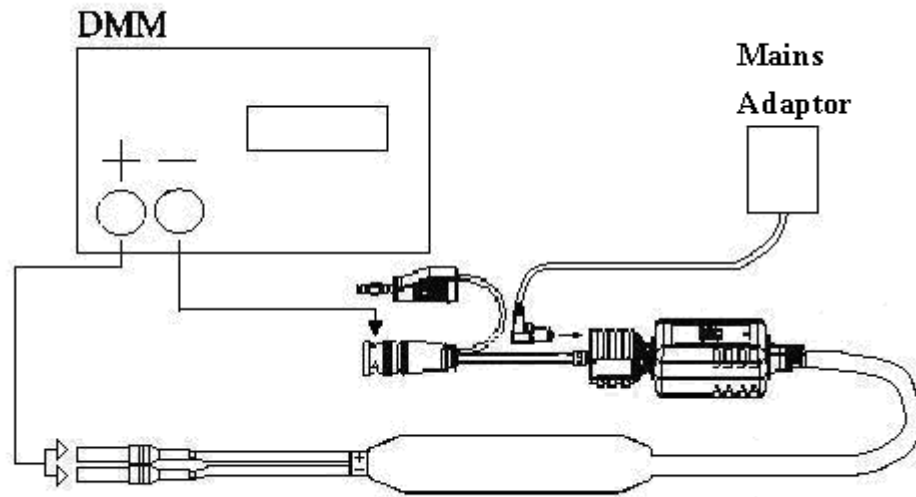

Fig. 3

C. Adjust output offset Voltage

- C-1. Connect the probe as shown in Fig. 4.
- C-2. Adjust VRC for minimum output offset voltage.
- C-3. The criterion is $-2 \text{ mV} \leq V_{out} \leq +2 \text{ mV}$.

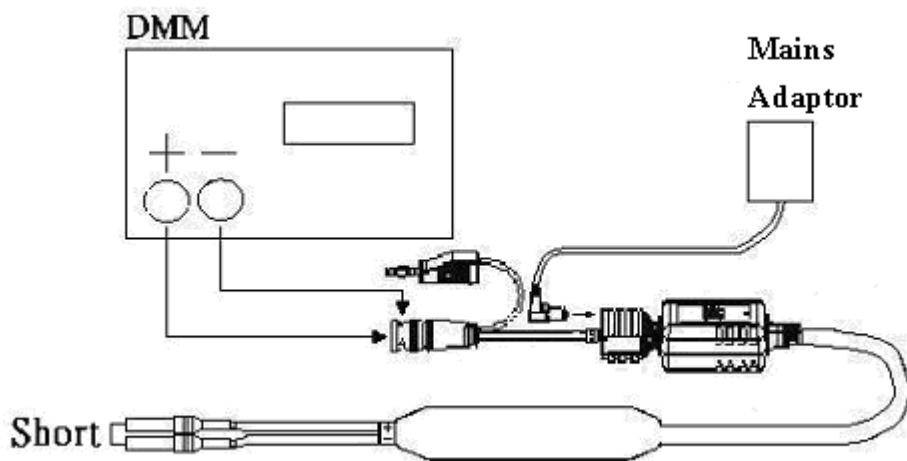

Fig. 4

D. Adjust square-wave compensation for + input.

D-1. Connect the probe as shown in Fig. 5.

D-2. Set the output of the function generator to 40 Vp-p, 1 kHz square-wave.

D-3. Set the input impedance of the oscilloscope to 1 M ohm.

D-4. Adjust VCA to make the front corner roll off or overshoot of the square-wave displayed on the oscilloscope less than 40 mV.

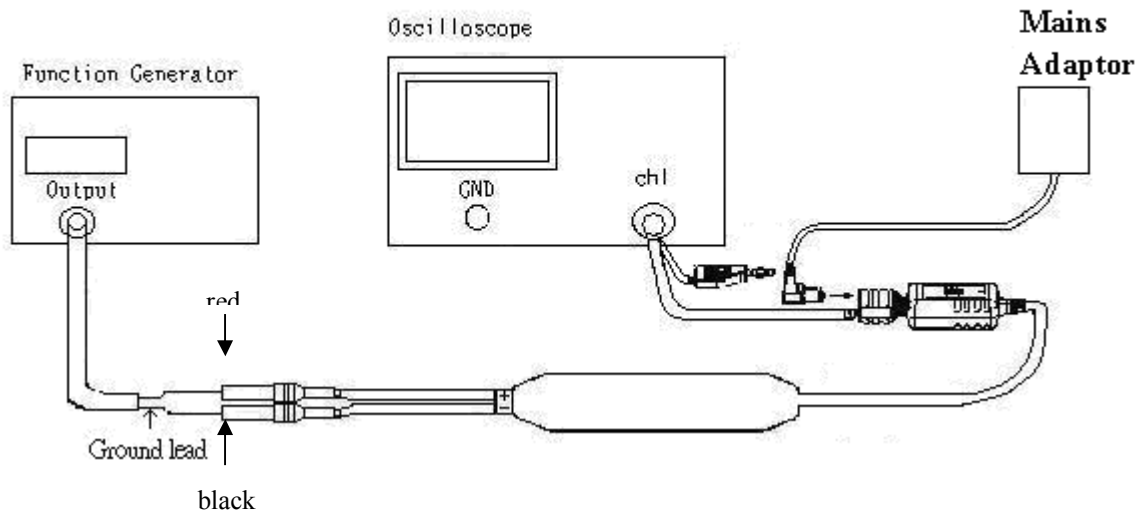

Fig. 5

E. Adjust square-wave compensation for - input.

E-1. Connect the probe as shown in Fig. 6.

E-2. Set the output of the function generator to 40 Vp-p, 1 kHz square-wave.

E-3. Set the input impedance of the oscilloscope to 1 M ohm.

E-4. Adjust VCB to make the front corner roll off or overshoot of the square-wave displayed on the oscilloscope less than 40 mV.

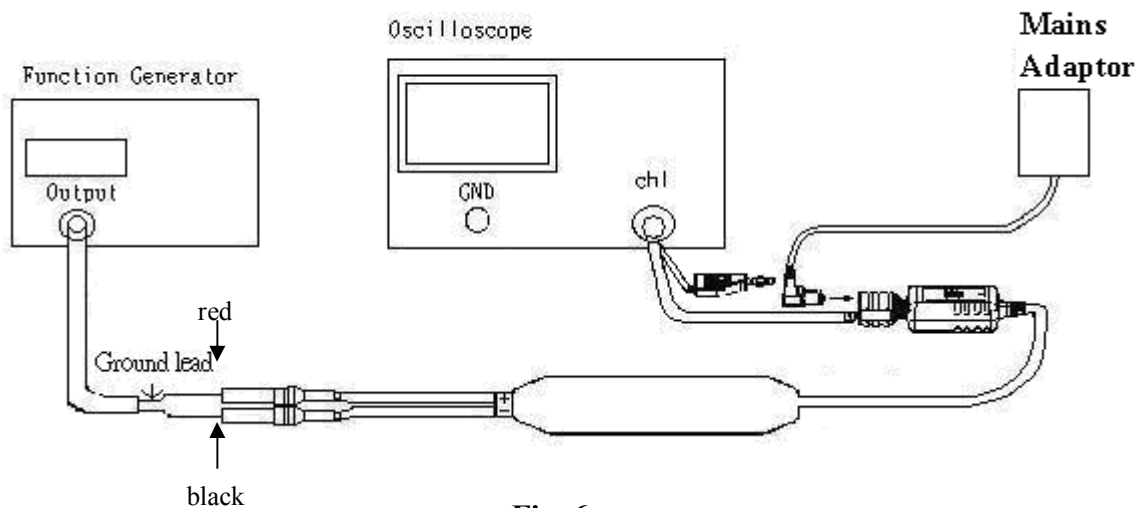

Fig. 6

F. Adjust CMRR at 60Hz

- F-1. Connect the probe as shown in Fig. 7.
- F-2. Set the output of the function generator to 620 Vp-p 60 Hz sine-wave, and set the input impedance of the oscilloscope to 50 ohm. (Add a feedthrough 50 ohm terminator to the input, if the oscilloscope doesn't provide the 50 ohm input impedance.)
- F-3. Adjust VRB for minimum Vout displayed on the oscilloscope.
- F-4. The criterion is $V_{out} \leq 2 \text{ mVp-p}$ (after excluding noise).

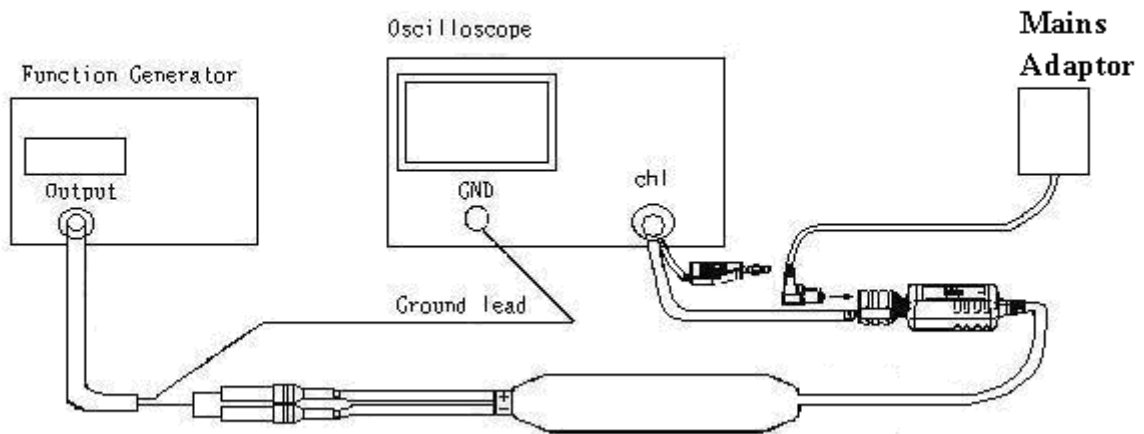

Fig. 7

G. Adjust CMRR at 1MHz

- G-1. Connect the probe as shown in Fig.8.
- G-2. Set the output of the function generator to be 20 Vp-p, 1 MHz, sine-wave, and set the input impedance of the oscilloscope to be 50 ohm (Add a feedthrough 50 ohm terminator to the input , if the oscilloscope doesn't provide the 50 ohm input impedance.)
- G-3. Adjust VCB slightly for minimum Vout displayed on the oscilloscope.
- G-4. The criterion is $V_{out} \leq 4 \text{ mVp-p}$ (after excluding noise).

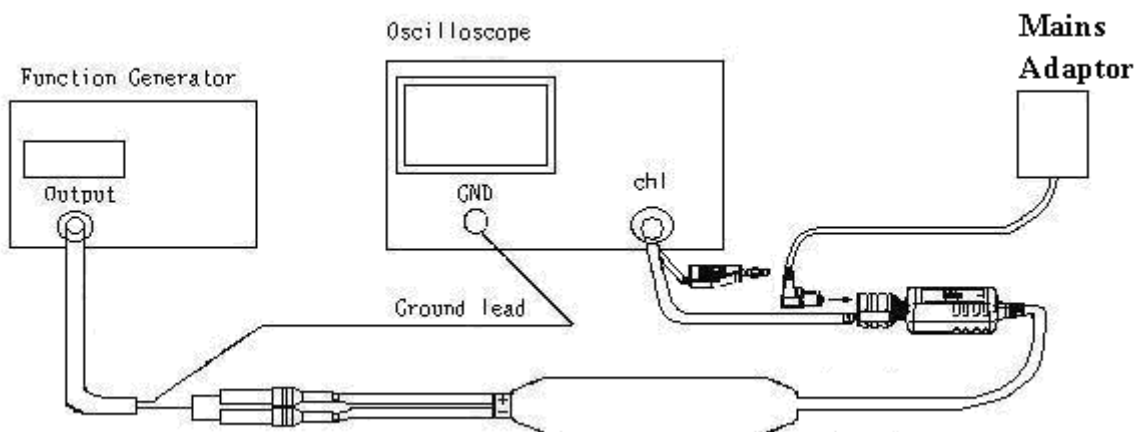

Fig. 8