

# 50MHz DIFFERENTIAL PROBE

## USER'S MANUAL[SI-51]

This probe is in compliance with IEC-61010-031 CAT I or CAT II, Pollution Degree 2.

### 1. Safety Terms and Symbols

Terms appear in this manual:



---

WARNING. Warning statements identify conditions or practice that could result in injury or loss life.

---



---

CAUTION. Caution statements identify conditions or practice that could result in damage to this product or other property.

---

Symbols appear on the product:



Danger  
High Voltage



Protective  
(Earth) Terminal



Attention  
Refer to Manual

### 2. General Safety Summary

Review the following safety precautions to avoid injury and prevent damage to this probe or any products that connected to it.

#### Observe Maximum Working Voltage

To avoid any injury, do not use the probe under following conditions, the voltage between either input lead and earth is above 600Vrms CAT II

## **Must be Grounded**

This probe is grounded with the shell of BNC connector and an auxiliary grounding terminal, through the grounding conductor of the power cord of the measurement instrument.

Before making connections to the input leads of this probe, ensure that the output BNC connector is attached to the BNC connector of the measurement instrument and the auxiliary grounding terminal is connected to a proper ground, while the measurement instrument is properly grounded.

## **Use Fused Test Prods if Necessary**

If this probe is intended to use for measurements in circuits of INSTALLATION CATEGORY III, it should incorporate with fused test prods.

## **Do Not Operate Without Covers**

To avoid electric shock or fire hazard, do not operate this probe with covers removed.

## **Do Not Operate in Wet/Damp Conditions**

To avoid electric shock, do not operate this probe in wet or damp conditions.

## **Do Not Operate in Explosive Atmosphere**

To avoid injury or fire hazard, do not operate this probe in an explosive atmosphere.

## **Avoid Exposed Circuit**

To avoid injury, remove jewelry such as rings, watches, and other metallic objects. Do not touch exposed connections and components when power is present.

## **Use Proper Power Source**

To ensure this probe function well, use four AA cells or 6VDC/90mA or regulated 9VDC/70mA mains adaptor or power lead.

## **Do Not Operated With Suspected Failures**

If you suspect there is damage to this probe, have it inspected by qualified service personnel.

### 3. Description

By enabling conventional oscilloscopes to display and measure in-circuit waveforms that are referenced to high common mode voltages, the differential probe extends the measurement capability of oscilloscopes in electronic power converters, inverters, motor speed controls, switch mode power supplies, and many other applications.

### 4. Installation

- a. Simply plug-in the BNC output connector to the vertical input of a general purposed oscilloscope or other measurement instrument, and connects the auxiliary grounding terminal to a proper ground. The measurement instrument must have a ground referenced.
- b. Connect an appropriate power source (mains adaptor, battery pack or power lead) to this probe and then turn it on.



---

WARNING. To protect against electric shock, use only the accessories supplied with this probe.

---

- c. Using the appropriate probe accessories, connect the inputs to the circuits under measurement.



---

CAUTION. This probe is to carry out differential measurement between two points on the circuit under measurement. This probe is not for electrically insulating the circuit under measurement and the measuring instrument.

---

## 5. Appearance

The differential probe looks as follows.

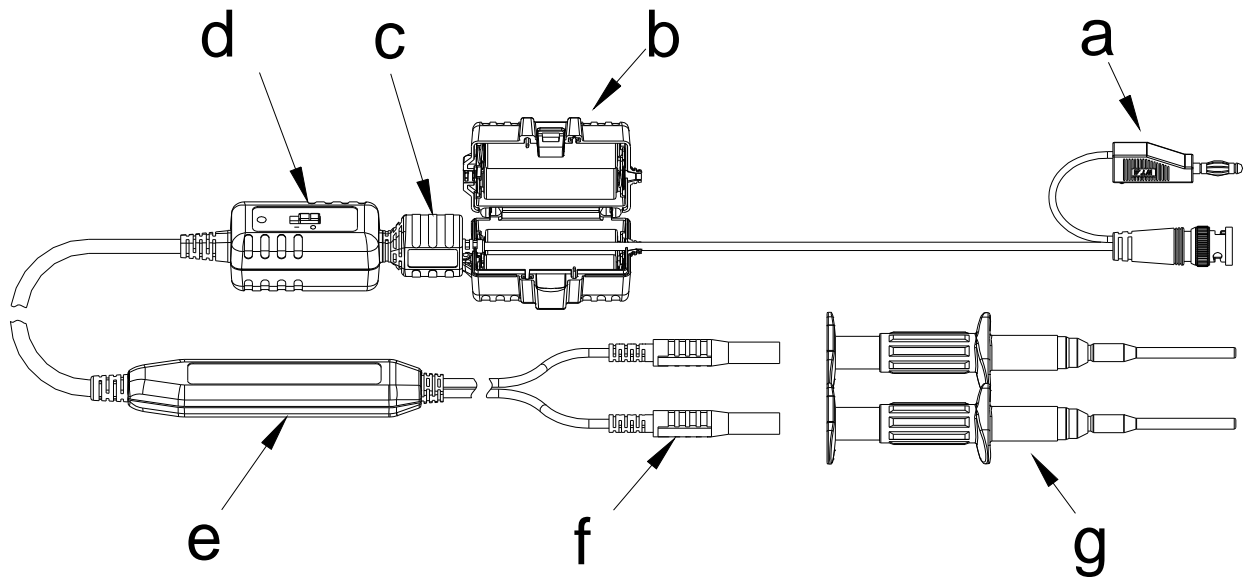

- a. Output Cable: The BNC output connector and an auxiliary grounding terminal are connected to the oscilloscope.
- b. Removable Battery Pack (optional): 4 x AA cells
- c. Power Source Connector:  
This connector can be connected to the following sources;
  - Mains adaptor (6VDC/90mA or regulated 9VDC/70mA)
  - Removable battery pack (4 x AA cells)
  - Power leads
- d. Power Supply
- e. Probe Body
- f. The input leads of the differential probe
- g. Sprung Hooks: The sprung hooks are connected safely to test points in circuits.

## 6. Power Leads

Two types of power leads are offered;

- a. Lemo<sup>®</sup> Lead: For the oscilloscope whose power connector is Lemo<sup>®</sup> connector.
- b. Probus<sup>®</sup> Lead: For the oscilloscope whose power connector is Probus<sup>®</sup> connector.

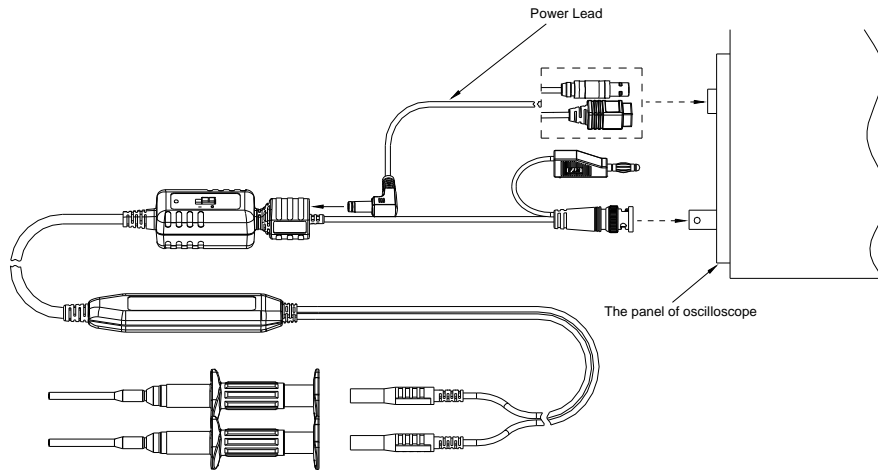

## 7. Removable Battery Pack

The following figure illustrates the operation of the removable battery pack;

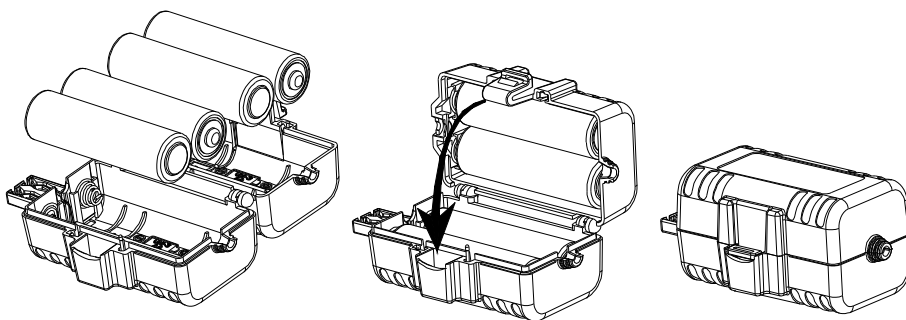

## 8. Specifications

Bandwidth	DC to 50MHz (-3dB)
Attenuation Ratio	1/100
Accuracy	±1%
Rise Time	<7ns
Input Impedance	4MΩ//7pF each side to ground
Input Voltage*	
- Category	CAT II
- Differential Range	±700V(DC+Peak AC) or 600Vrms
- Common Mode Range	±1400V(DC+Peak AC) or 600Vrms
- Absolute Max. Voltage (Differential or Common Mode)	±1400V(DC+Peak AC) or 600Vrms
Output	
- Swing (into 5kΩ load)	±7V
- Offset (typical)	<±1mV
- Noise (typical)	0.3mVrms
- Source Impedance (typical)	50Ω (for using 1MΩ input system oscilloscope)
CMRR (typical)	-90dB @60Hz, -55dB @1MHz
Power Requirements**	Mains adaptor (6VDC/90mA or 9VDC/70mA)
(Three options of power sources)	Removable battery pack (4xAA cells) Power leads
Optional Extension plugs for mains adaptor	
- Input	One jack of 1A current rating.
- Output	Three plugs of 1A current rating.
Ambient Operating Temperature	-10 to 40
Ambient Storage Temperature	-30 to 70
Ambient Operating Humidity	25 to 85% RH
Ambient Storage Humidity	25 to 85% RH
Length of BNC Cable	125cm
Length of Input Leads	50cm
Weight	300gms
Dimensions (LxWxH)	111mm x 22mm x 14mm

\* Voltage limit is the lesser of the DC+Peak AC and RMS values..

- \*\*
- The supplied voltage must be less than 16V and greater than 3.3V, otherwise the probe could be damaged or can't be operated properly.
  - For wrong polarity of power sources, a built-in circuit will protect the probe and no danger or damage will occur.
  - When the voltage of the cells become too low, the power indicator on the panel will dim and

then distinguish.

## 8. Derating Curve

The derating curve of the absolute maximum input voltages (either input to ground) is illustrated as follows;

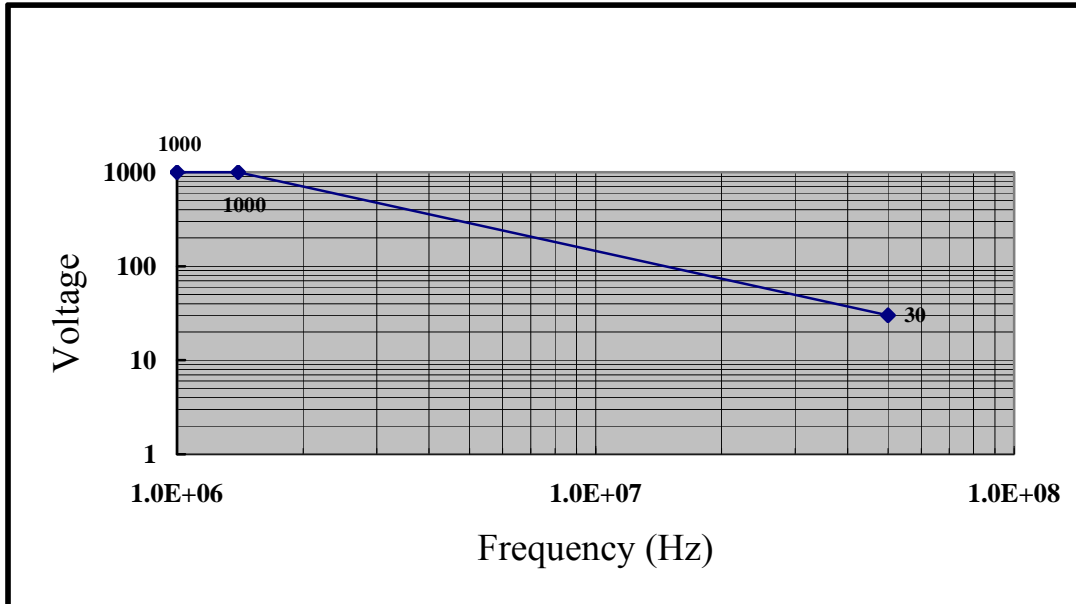

## 9. Inspection Procedure

- Connect the BNC output connector to the vertical input of a general purposed oscilloscope.
- Connect an appropriate power source to this probe and then turn it on.
- Set the oscilloscope to DC coupling and 1V/div. Center the trace on the display.
- Connect the inputs of the probe to power lines.
- Then, a 50Hz/60Hz sine-wave of proper amplitude will be displayed on the screen of the oscilloscope and this means the probe is working properly.

## 10. Cleaning

Use a soft cloth to clean the dirt. Prevent damage to probe.

- Avoid immersing the probe.
- Avoid using abrasive cleaners.
- Avoid using chemicals contains benzene or similar solvents.