

S a p p h i r e I n s t r u m e n t s C o . , L t d .

Calibration Procedure of SI-50

This procedure is for use by qualified service personnel to adjust SI-50 properly. The equipments required are listed in Table 1.

No.	Item	Minimum Requirements
1	Power Supply	6VDC/90mA or 9VDC/330mA mains adaptor or 4xAA cells or power lead
2	DMM	DC Accuracy < 0.5%
3	Function Generator	Maximum Frequency > 10MHz Sine-wave Distortion < 1%
4	Oscilloscope	Bandwidth >= 20MHz Accuracy <= 2%

Table 1

This procedure is divided into following steps;

- A. Prepare the probe for adjustment.
- B. Adjust input bias voltage.
- C. Adjust output offset voltage.
- D. Adjust CMRR at 60Hz.
- E. Adjust square-wave compensation for +input.
- F. Adjust square-wave compensation for -input.
- G. Adjust CMRR at 1MHz.

A. Prepare the probe for adjustment.

A-1. Use a small flat screwdriver to peel the both panels off, referring to figure 1.

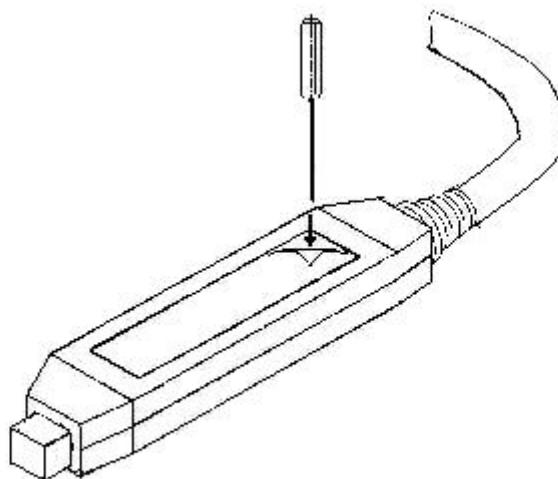

Fig. 1

- A-2. Loosen the four screws on the plastic cases.
- A-3. Remove the plastic cases. Figure 2 shows the location of adjustments on topside and bottom side of the metal case.
- A-4. Connect the power source.
- A-5. Allow the probe and test equipments to warm up 20 minutes at an ambient temperature of 18 degree Celsius to 28 degree Celsius.
- A-6. In order to make following operation easier, use one plastic case to support the metal case and the input head.

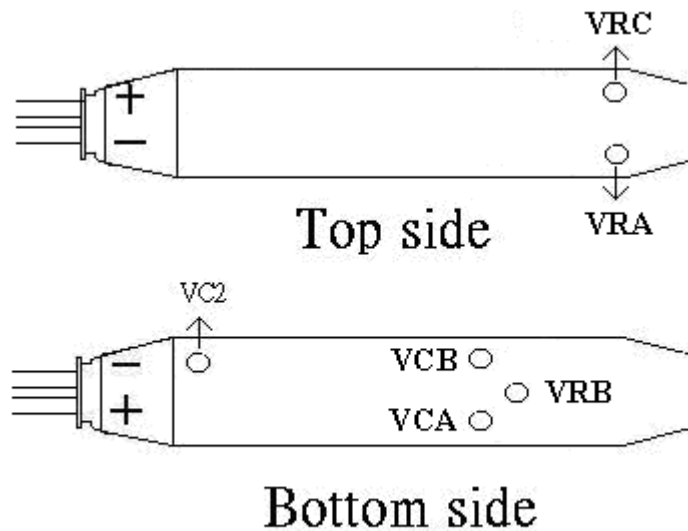

Fig. 2

B. Adjust input bias voltage

- B-1. Connect the probe as shown in figure 3.
- B-2. The value of input bias voltage now is displayed on the digital multimeter.
- B-3. Adjust VRA to make the input bias voltage as small as possible.
- B-4. The criterion is $-3\text{mV} \leq V_{ib} \leq +3\text{mV}$.

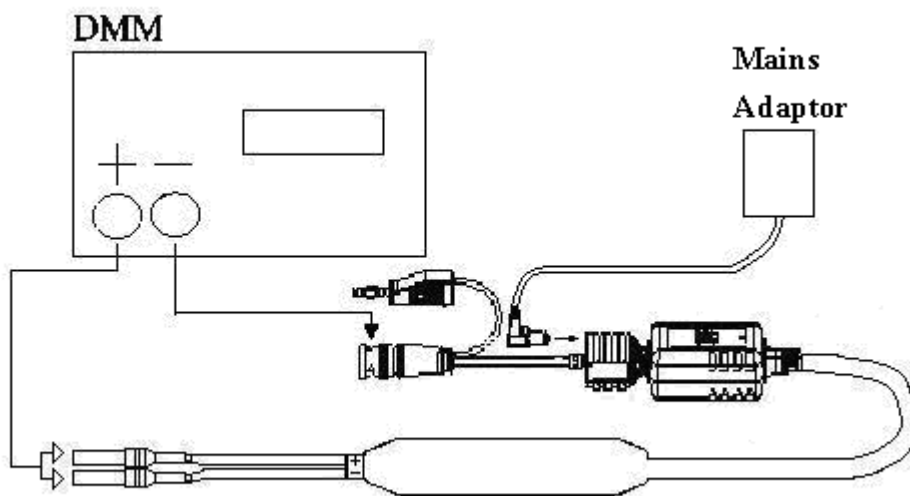

Fig. 3

C. Adjust output offset Voltage

- C-1. Connect the probe as shown in figure 4.
- C-2. Adjust VRC for minimum output offset voltage.
- C-3. The criterion is $-2\text{mV} \leq V_{\text{out}} \leq +2\text{mV}$.

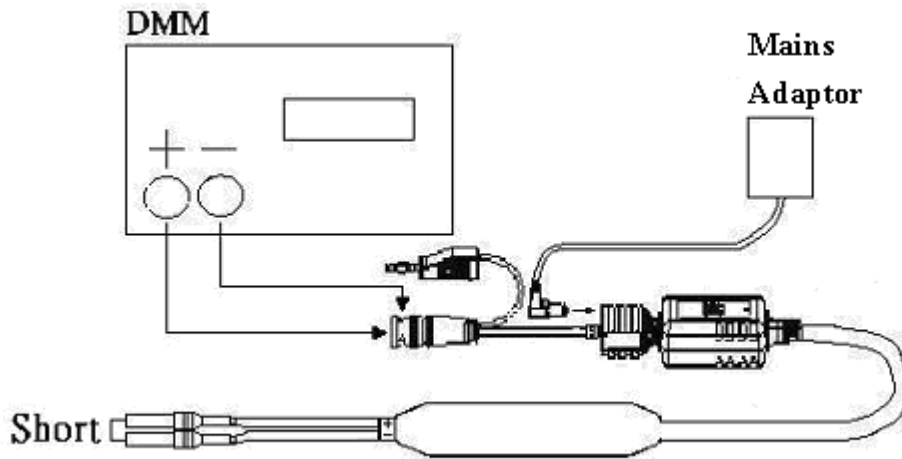

Fig. 4

D. Adjust CMRR at 60Hz

- D-1. Connect the probe as shown in figure 5.
- D-2. Set the output of the function generator to 620Vp-p 60Hz sine-wave, and set the input impedance of the oscilloscope to 50ohm. (Add a feedthrough 50ohm terminator to the input, if the oscilloscope doesn't provide the 50ohm input impedance.)
- D-3. Adjust VR1 for minimum V_{out} displayed on the oscilloscope.
- D-4. The criterion is $V_{\text{out}} \leq 2\text{mVp-p}$.

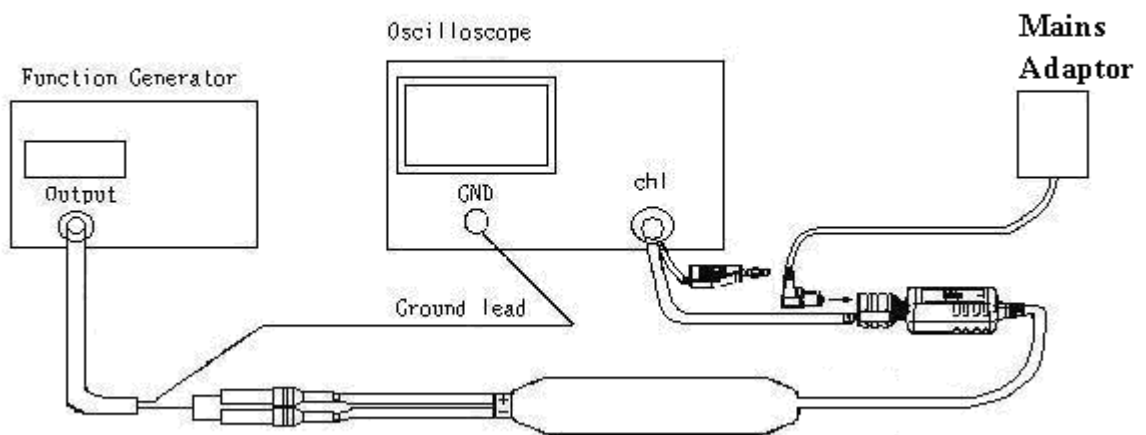

Fig. 5

E. Adjust square-wave compensation for +input.

- E-1. Connect the probe as shown in figure 6.
- E-2. Set the output of the function generator to 40Vp-p, 1KHz square-wave.
- E-3. Set the input impedance of the oscilloscope to 50ohm (Add a feedthrough 50ohm terminator to the input, if the oscilloscope doesn't provide the 50ohm input impedance.)
- E-4. Adjust VCA to make the front corner roll off or overshoot of the square-wave displayed on the oscilloscope less than 40mV.

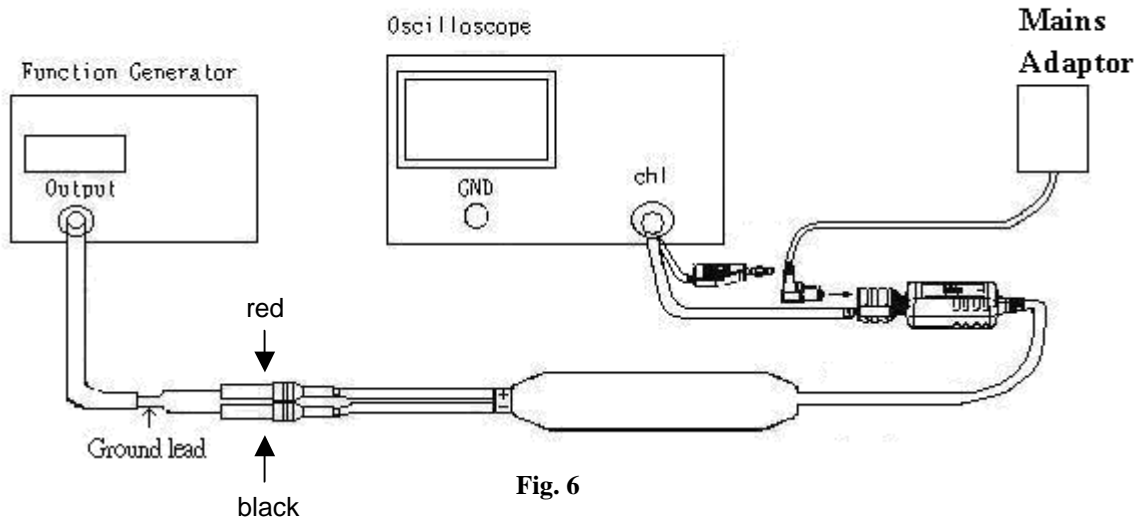

Fig. 6

F. Adjust square-wave compensation for -input.

- F-1. Connect the probe as shown in figure 7.
- F-2. Set the output of the function generator to 40Vp-p, 1KHz square-wave.
- F-3. Set the input impedance of the oscilloscope to 50ohm (Add a feedthrough 50ohm terminator to the input, if the oscilloscope doesn't provide the 50ohm input impedance.)
- F-4. Adjust VCB to make the front corner roll off or overshoot of the square-wave displayed on the oscilloscope less than 40mV.

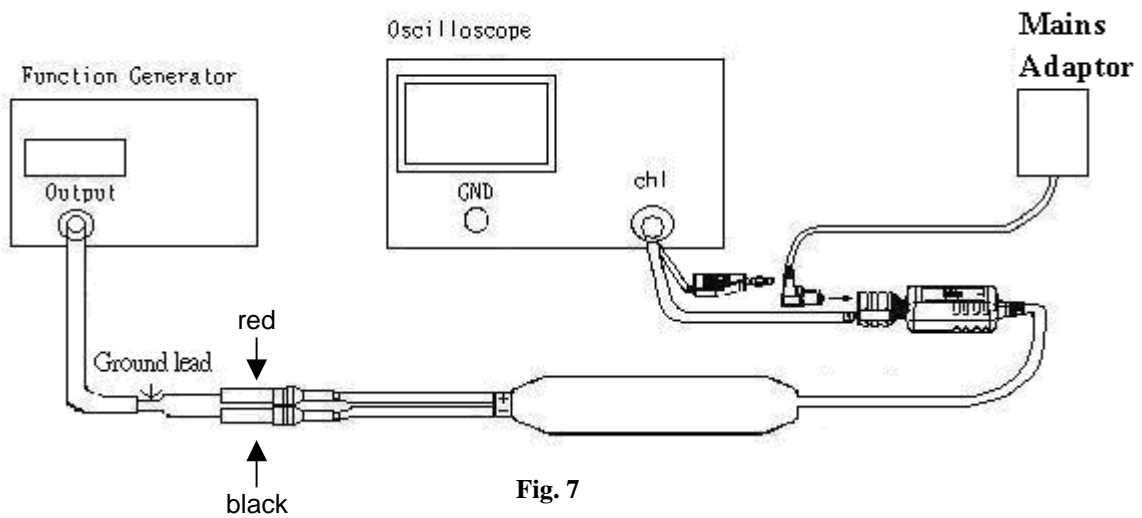

Fig. 7

G. Adjust CMRR at 1MHz

- G-1. Connect the probe as shown in figure 8.
- G-2. Set the output of the function generator to be 20Vp-p, 1MHz, sine-wave, and set the input impedance of the oscilloscope to be 50ohm (Add a feedthrough 50ohm terminator to the input , if the oscilloscope doesn't provide the 50ohm input impedance.)
- G-3. Adjust VC1 slightly for minimum Vout displayed on the oscilloscope.
- G-4. The criterion is $V_{out} \leq 4mV_{p-p}$.

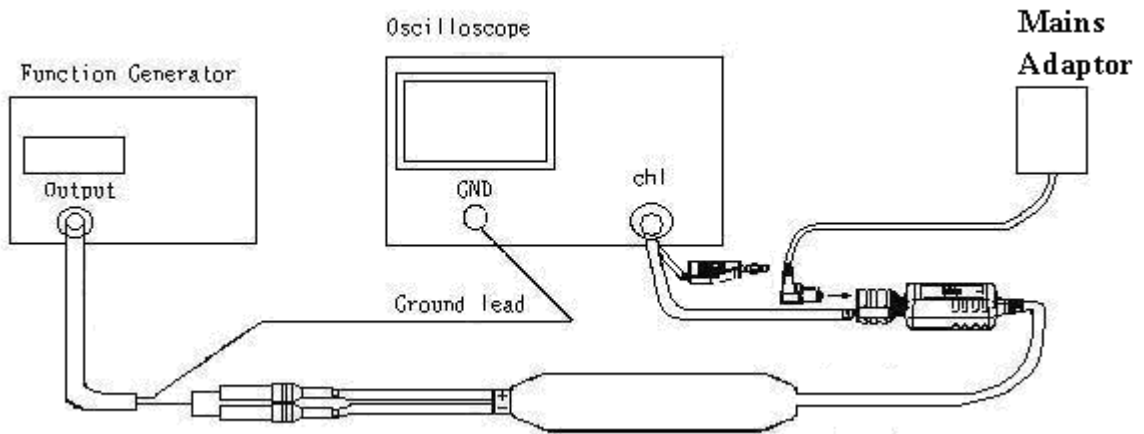

Fig. 8